

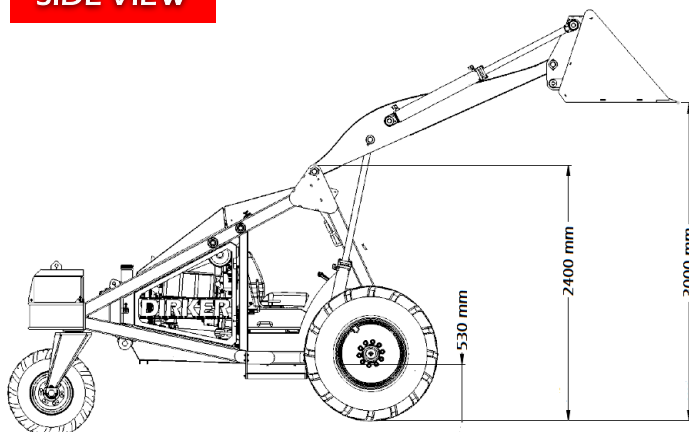

# MULTI - LIFT

AN AGILE MULTI PURPOSE LIFTING AND LOADING SOLUTION

SIDE VIEW



TOP VIEW

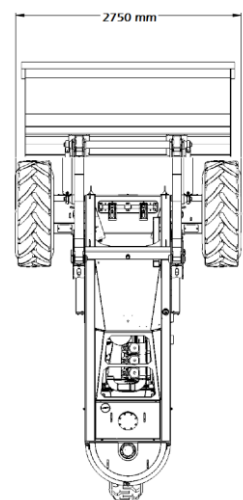

# MULTI LIFT SPECIFICATION SHEET

## ALL DIRKER MACHINES CAN BE BUILT TO SUIT CUSTOMER SPECIFIC REQUIREMENTS

### ENGINE

MAKE :	DEUTZ F4L912	CYLINDERS QTY :	4
POWER :	49KW / 230NM @ 1600RPM	SAFETY :	MECHANICAL SHUT OFF
RPM :	GOVERNED @ 2300RPM	MOUNTING :	6 POINT RUBBER MOUNT

### TRANSMISION PUMP

MAKE :	POCLAIN	CONFIGURATION :	TANDEM PISTON PUMP
OPERATOR CONTROL :	SERVO FOOT PEDAL	COOLING/FLUSHING :	PUMP INTERNAL
DISPLACEMENT :	45 cc PER SIDE	DRIVE COUPLING :	GUARDEX NYLON
RELIEF VALVE :	280 BAR	SAFETY :	OPERATOR INPUT CUT OFF

### WHEEL DRIVE SYSTEM

CONFIGURATION :	HYDRAUSTATIC WHEEL MOTOR	WHEEL RPM :	32 RPM @ 2300 ENGINE RPM
MAKE :	POCLAIN	DRIVE MOTOR QTY :	2
WHEEL TORQUE :	13300 NM PER WHEEL		

### AUXILIARY HYDRAULIC SYSTEM

CONFIGURATION 1 :	GEAR PUMP	CONFIGURATION 2 :	GEAR PUMP
OPERATING PRESSURE :	140 BAR	OPERATING PRESSURE :	140 BAR
OPERATOR CONTROL :	SINGLE LEVER VALVE	OPERATOR CONTROL :	SINGLE LEVER VALVE
COOLING :	ELECTRIC FAN COOLED OIL COOLER		

### BRAKE SYSTEM

PARK BRAKE TYPE :	MULTI DISC SPRING APPLIED	SERVICE BRAKE :	HYDRAUSTATIC
PARK BRAKE RELEASE :	HYDRAULIC PRESSURE RELEASE	OPERATOR CONTROL :	FOOT PEDAL
OPERATOR CONTROL :	MECHANICAL LEVER VALVE		

### HYDRAULIC AND FUEL TANK

HYD TANK TYPE :	FRAME TUBING INTEGRATED	FUEL TANK TYPE :	BOLT MOUNTED ON FRAME
HYD TANK CAPACITY :	145L ( 170L FOR SYSTEM )	FUEL TANK CAPACITY :	85 L

### CABIN

TYPE :	FRAME INTEGRATED	OPTIONAL 1 :	SEALED CABIN
OPERATOR ACCESS :	LEFT & RIGHT SIDE	OPTIONAL 2 :	AIRCON SYSTEM
SAFETY : 1	SUSPENDED LAP BELT	OPTIONAL 3 :	4 POINT OPERATOR HARNESS
SAFETY 2 :	FRONT OPERATOR GUARD		

### ATTACHMENT

ATTACHMENT 1 :	LOADER BUCKET	ATTACHMENT 2 :	FORKLIFT FORKS
----------------	---------------	----------------	----------------

### OPERATING MASS

FRONT UNLADEN :	2100KG	TOTAL UNLADEN :	4560KG
REAR UNLADEN :	1850KG	LIFTING CAPACITY :	2500KG

### WHEELS

FRONT TYRES :	17.5 X 25	FRONT RIMS :	17.5 3 PIECE
REAR TYRE :	400/60 X15.5	REAR RIM :	15.5 1 PIECE

# SALES & RENTALS

BRIAN BOSHOF | +27 ( 0 ) 83 948 8332 |  
| +27 ( 0 ) 12 942 1446 |  
brian@forkliftmaster.co.za | www.forkliftmaster.co.za  
PRETORIA, SOUTH AFRICA