

DIRKER
RUGGED > AGILE > EVOLUTION

**ALL TERRAIN
LIFTING SOLUTIONS**

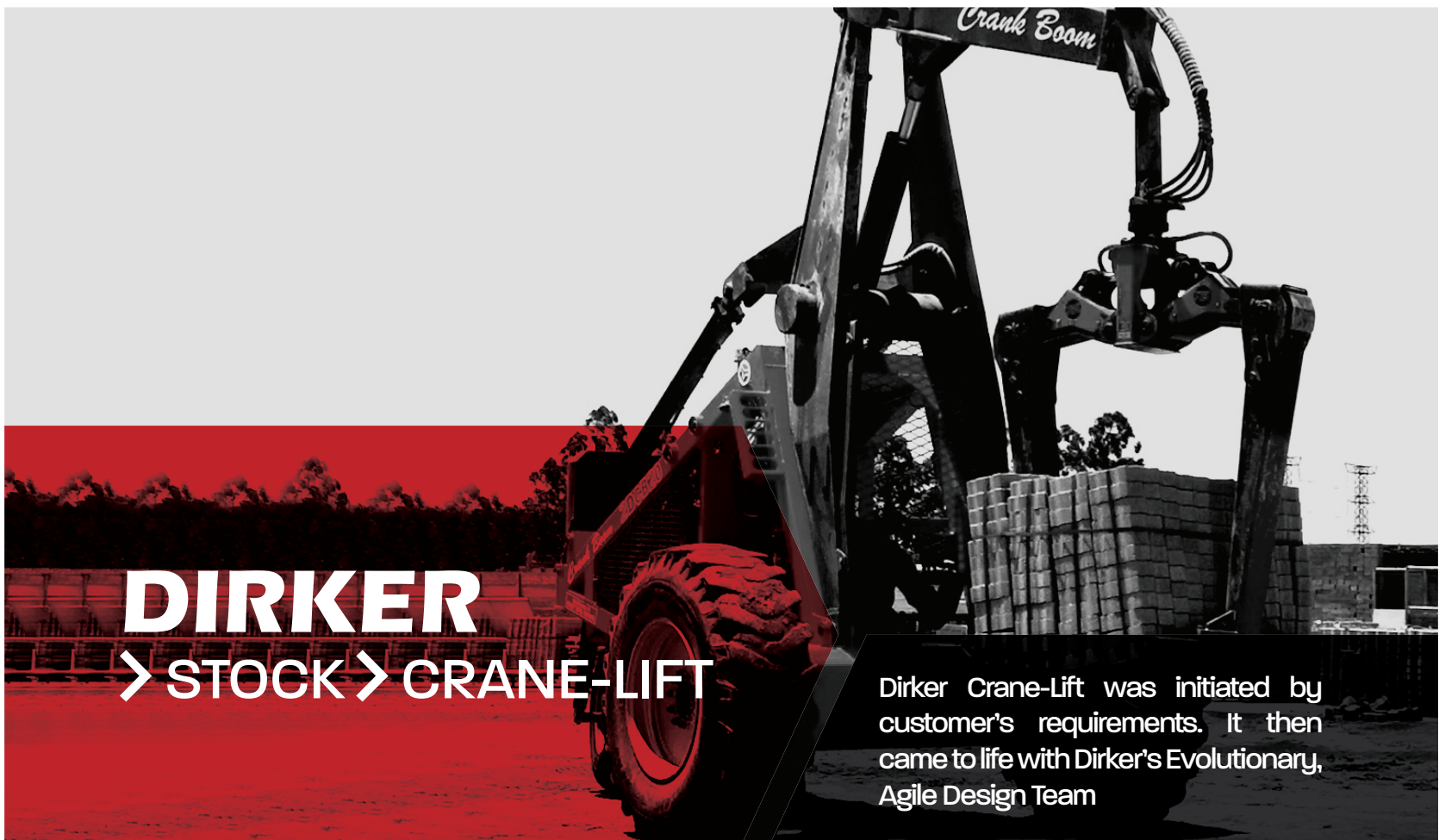

DIRKER
> STOCK > CRANE-LIFT

Dirker Crane-Lift was initiated by customer's requirements. It then came to life with Dirker's Evolutionary, Agile Design Team



> APPLICATION

The Dirker Crane-Lift is designed to reach up to 3 m and lift up to 6 m. With Nose end attachments designed to specific application requirements. The Dirker Crane-Lift can be adapted and be used in Saharan to Siberian conditions, in industries such as:

- Agricultural
- Forestry & Sawmills
- Construction
- Mining
- Defence Forces

Contact us for more information regarding the applications of the Dirker Crane-Lift

> EVOLUTION

The Dirker Crane-Lift is a perfect example of the evolution team in action. We are still ready to evolve even more to implement your ideas and requirements.

Due to the Dirker Evolution design and manufacturing's teams ability to create solutions, as well as the ability to take any idea from concept to final product extremely fast.

+27 (0) 12 942 1446 | sales@dirkermachines.com
www.dirkermachines.com | Pretoria, South Africa

1900MM

2700MM

2560MM



CRANE-LIFT SPEC SHEET

ENGINE		DRIVE PUMP	
Make	Deutz F4L912	Model	PMP 50x50
Power	49Kw/230nm @ 1600rpm	Operator Control	Servo Foot Pedal
RPM	Governed @ 2300rpm	Displacement	45cc Per Side
Mounting	6 Point Rubber Mount	Relief Valve	280 Bar
Safety	Mechanical Shut Off	Hot Oil Shuttle	Pump Internal
HYDRAULIC & FUEL TANK		WHEELS	
Hyd Tank Type	Framing Tubing Integrated	Front Tyres	17.5x25
Hyd Tank Capacity	145L (170 for System)	Front Rim	17.5" Three Piece
Fuel Tank Type	Bolt Mounted on Frame	Rear Tyres	400/60x15.5
Fuel Tank Capacity	85L	Rear Rim	15.5 One Piece
BRAKES		OPERATING MASS	
Park Brake	Muli Disc Spring Applied	Front Unladen	2100KG
Park Brake Release	18 Bar Hydraulic Pressure	Rear Unladen	1850KG
Park Brake Valve	Mechanical	Total Unladen	4560KG
Service Brake	Hydrostatic Foot Pedal Control	Lifting Capacity	Up To 3000KG
CABIN		ATTACHMENT	
Type	Frame Integrated	Type	Brick Grab
Optional Protection	Guarded Sided Doors	Rotator	5 Ton Rotator
	Front Top Guard	AUX HYDRAULIC SYSTEM	
	Front Bottom Guard	Pump	28cc Gear Pump
Seat Belt	Suspended Lap Belt	Operating Pressure	170 Bar
HVAC Cabin	Optional	Oil Cooler	Electric Fan Cooled
Type	Sealed Frame Integrated	Control Valves	1 x Double Left Hand
HVAC System	12v Fan, Engine Belt Drive Aircon Compressor		1 x Double Right Hand
Windows	Glazed With Wiper		
WHEEL DRIVE SYSTEM			
Drive Motor	Poclain MS18 2800cc	Wheel RPM	32rpm @ 2300 Engine RPM
Wheel Torque	13300nm Per Wheel		

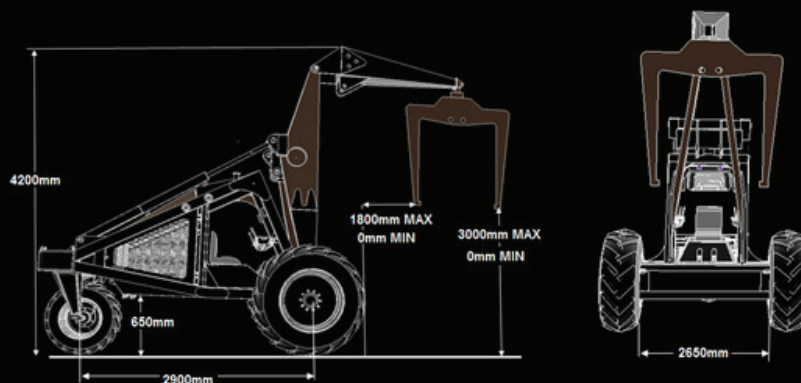

SALES & RENTALS

+27 (0) 12 942 1446 | sales@dirkermachines.com
www.dirkermachines.com | Pretoria, South Africa